



A.O. Smith
Motor
Mastery
University

PUMP MOTORS

APPLICATION

INCLUDES:

SWIMMING POOLS

SPA & JETTED TUB

JET PUMPS

INSTALLATION TIPS

REPAIR

TROUBLESHOOTING

OTHER MODULES INCLUDE:

HEATING, VENTILATION,
AIR CONDITIONING &
REFRIGERATION MOTORS

GENERAL PURPOSE MOTORS

SPECIAL PURPOSE MOTORS

NOTICE: The information contained in this booklet is general in nature and is drawn from sources believed to be reliable. It is intended for general information purposes only. The descriptions in this booklet may not apply to a particular motor or a particular application. No warranties are intended to be created by this information.

Contents

Pump Motors

<i>Introduction</i>	1
<i>Motor Replacement</i>	6
<i>Swimming Pool, Spa and Jetted Tub Motors</i>	7
<i>Voltage</i>	10
<i>Service Factor</i>	11
<i>Jet Pumps</i>	13
<i>Motor Troubleshooting Guide</i>	19
<i>Recommended Wire Size</i>	20
<i>Failure to Start</i>	20
<i>Overheating</i>	21
<i>Noisy Operation</i>	23
<i>Electrical Shock</i>	23
<i>Protect Against Moisture</i>	23
<i>Protect Against Dirt & Chemicals</i>	24
<i>Conventional Multimeter or Ohmmeter</i>	25
<i>Digital Ohmmeter/Multimeter</i>	25
<i>Ammeter and Voltmeter</i>	25
<i>Voltage Check</i>	26
<i>Amperage Check</i>	26
<i>Start Switch Check</i>	27
<i>Start Switch Adjustment</i>	27
<i>Motor Component Checks</i>	29
<i>Ground Check</i>	29
<i>Winding Continuity</i>	30
<i>Capacitor</i>	31
<i>Switch</i>	31
<i>Protector (Thermal Overload)</i>	32
<i>Pump Disassembly</i>	32
<i>Single Speed Motor — Typical Schematic Diagrams</i>	33
<i>Motor Assembly</i>	36
<i>How To Replace Bearings</i>	37
<i>Bearing Information Table</i>	39
<i>Recommended Tools</i>	39
<i>Motor Reassembly</i>	40
<i>2-Speed Motors</i>	40
<i>Start Switch Replacement and Adjustment — 2-Speed Motors</i>	41
<i>Switch Connections High Speed Start</i>	42
<i>Switch Connections Low Speed Start</i>	43
<i>2-Speed Motors High Speed Schematic Diagram (Remote Switch Operation)</i>	44
<i>2-Speed Motors Hi-Low Switch Reconnection</i>	45
<i>2-Speed Motors Hi-Low Switch Reconnection</i>	46

Introduction

The motors discussed in this application module are those commonly found on swimming pools, spas, jetted tubs, home water systems and other centrifugal pumps. The motors are 48 and 56 frame used to pump water.

MOTOR TYPES

There are five distinct electrical designs which may be found on some or all of the pumps being discussed.

1. Split Phase

This type is used extensively in spa, jetted tub and above ground pool pump applications. Some are used on the lower end of in ground pool and jet pumps. This design has a start winding and start switch, but no capacitors.

2. Capacitor Start

This is the most common single phase motor found on in ground pool and jet pump applications. The starting torque is higher (150-175% of full load) and starting current lower than the split phase equivalent. The operation is similar to the split phase in that there is a start switch to take the start winding and capacitor out of the circuit once the motor reaches 2/3 to 3/4 of full speed.

3. Permanent Split Capacitor (PSC)

This design does not have a start switch, but uses a run capacitor that remains in the circuit at all times. However, the run capacitor is more expensive than a start capacitor, and the PSC design has only approximately 40% of the starting torque of a capacitor start design.



ST1302
CAP START/RUN

4. Capacitor Start/Capacitor Run
This design is used to increase efficiency in the run mode. Both start and run capacitors are used.
5. Polyphase (3 Phase)
This is the simplest, most efficient design. Its use is limited to commercial and industrial applications since three phase power is not available in residential areas.

These same motors may sometimes be applied to pumps used in other applications where the selection and troubleshooting procedures are similar, but the application has specific considerations due to the fluid being pumped or the operating environment.

Underwriter's Laboratories has established safety standards for many pump motors. Standard 1081 applies to swimming pool motors and Standard 778 applies to jet pump motors.

The motors are two pole (3450 RPM) designs or two pole/four pole (1725 RPM) designs. The two pole design is used because it runs cooler and moves more water.

Typical pump motors discussed here use ball bearings at each end of the shaft, one of which is locked to take any thrust loading. Some pump motors have had ball/sleeve bearing construction. Jet pump motors typically have double shielded bearings and pool pump motors typically have double sealed bearings. Both types are permanently lubricated and neither type is waterproof.



PT1072
PARTIAL MOTOR

Some pumps utilize a partial motor where the pump provides the shaft extension bearing bore. This type of construction is not popular, and replacement usage has fallen dramatically. Some replacement motors are still available. Two basic types were used in the past. The difference is the length of the shaft extension.

The overloads or protectors used on pump motors are tested on an eighteen day locked cycle test. The eighteen days simulates a two week vacation plus weekends and a couple of extra days. During the test, the motor shaft is locked and power is applied to the motor. Since the motor cannot start, it will heat up rapidly and the overload will take it off line. After the overload resets, the cycle is repeated. The motor must operate at the end of the test.

If a motor does not operate because the overload has failed you should look for other problems. Its failure is often a symptom of another problem.

The pumps are designated centrifugal since the motor spins an impeller which moves the water by centrifugal action.

Pumps used in these applications are classified as centrifugal pumps. A centrifugal pump derives its name from the principal known as centrifugal force.

A centrifugal swimming pool pump, in its simplified form, consists of two components. One component is stationary and serves as the housing. It is known as the volute. Inside the volute is the rotating component known as the impeller which is driven by a motor. The motor is the "work horse" of the pump while the impeller is the "cartwheel" that moves the water.

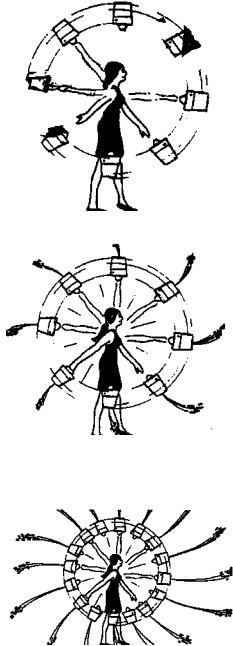

The principle of operation can be demonstrated by a whirling bucket of water. As the bucket is rotated (figure 1), the water is held in the bucket by centrifugal force. If we were to punch a hole in the bottom of the bucket, the water would be forced out, again by centrifugal force (figure 2). Speeding up the rotation of the bucket, the water would exit with greater force (figure 3).

This same principle is performed by the impeller of the pump. As the motor turns the impeller, the water is forced through the impeller vanes toward the outside edge (figure 4). The spinning action of these vanes generates centrifugal force (figure 5). This action imparts kinetic or velocity energy into the water. As the water is propelled to the outer edge of the impeller, there is a reduction in pressure at the eye of the impeller, creating a "vacuum" (figure 6).

The combination of atmospheric pressure on the surface of the water and vacuum at the eye of the impeller, causes the water to flow in the "suction pipe" to the pump.

The amount of pressure imparted into the water by the impeller is determined in part by the size and design of the impeller which also effects forces placed on the motor. There are basically two types of impellers used on these applications; the semi-open has vanes exposed on the front or receiving side. The back side is closed by a shroud (figure 7). A closed impeller is designed to have two shrouds completely enclosing the vane area of the impeller (figure 8).

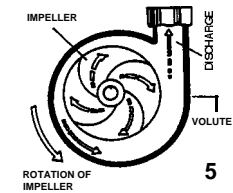
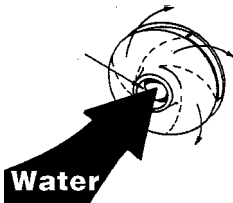

5

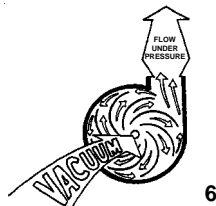

6

Pump Motors

5

An open impeller puts a great deal more force on the motor bearings than does the closed impeller. A 203 bearing is often used with closed impeller pumps while open impeller may require a larger 304 bearing on shaft end. Closed impeller pumps are used extensively today.

The performance of the pump and motor is affected by another major factor, the speed at which the impeller is driven. The capacity of an impeller varies in proportion to the change in its speed.

EXAMPLE:

The capacity of an impeller is 50 gallons per minute at a motor speed of 3450 RPM. Its capacity will drop to 25 GPM if the motor speed is reduced to 1725 RPM.

The above example is what takes place when using a 2-speed motor (3450/1725) for energy savings during low traffic periods on pool or spa motors. The load on the motor is reduced drastically but you also do not get the turn-over rate of the high speed.

In the original applications, each motor is tested with a specific pump, under a range of operating conditions. Each impeller requires a specific amount of horsepower to turn at a given speed. If a weaker replacement motor is selected the pump's output will not just be reduced, the motor will be overloaded. The motor is trying to run at its normal speed around 3450 RPM, and the impeller needs more power to be driven at that speed. If a stronger motor is selected, there will not be a significant increase in the pump's output. The stronger motor may run a little faster, but the impeller does not need the added horsepower to run around 3450 RPM. In summary, the motor and impeller should be considered a matched set.

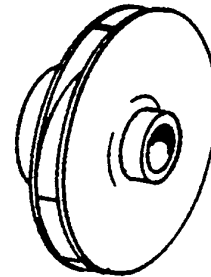
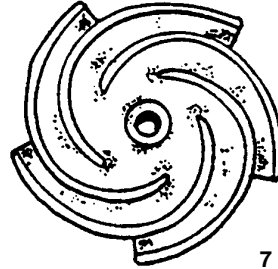

Replacement Motor Selection

REPLACEMENT MOTOR SELECTION

The nameplate on the motor being replaced contains much of the critical information needed to select a new motor. Some of the nameplate data detailed in the Replacement Module is repeated below in order to reemphasize its importance to the application.

Choosing the right replacement motor is easy using these 5 steps:

1. **Know which end frame you need.** Is it:

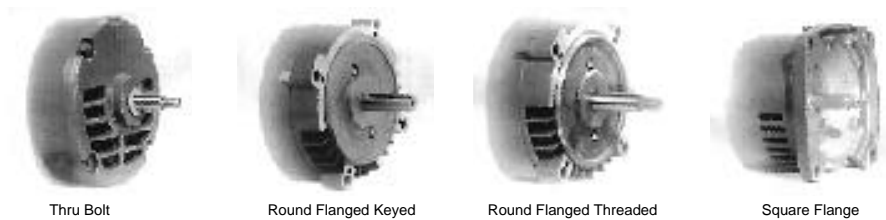

1081 DESIGN	ST 1072	
THERMALLY PROTECTED	SKCET53ABN	
MOD. C48K2N117A3	SER 8K00	
VOLTS 115/230	ENCL = DP	HP 3/4
ROT = CCWPE	PH 1	CODE L
RPM 3450	FR 56J	HZ 60
MAX LOAD AMPS 14.6/7.3	SF 1.5	
INSUL CLASS B	AMB 50 °C	TIME RATING CONT.
TYPE UAC	A.O.SMITH CORP. MEXICO	

2. **Know the total horsepower output.**

Find it on the motor's nameplate. Use this equation:
The total horsepower times (x) the service factor of the replacement motor must be equal to or greater than that of the original motor being replaced.

3. **What is the original motor single or three phase?**

The original and replacement motors must be the same unless the power supply is being changed.

4. **What is the correct voltage?**

The operating voltage of the replacement motor must match the voltage of the original motor. A single voltage motor is an acceptable replacement for a dual voltage motor and vice versa.

5. **What is the motor's cycle or hertz?**

As a general rule, 50-cycle motors should not be substituted for 60-cycle motors and vice versa.

**SWIMMING POOL, SPA
AND JETTED TUB MOTORS**

Applications include in-ground pools, above ground pools and pool cleaners.

There are no efficiency standards for single phase motors. Motors designated high efficiency by a motor manufacturer are just more efficient than their standard motors. Swimming pool pumps are an excellent application for high efficiency motors since they typically run many hours a day, even continuously. Compare the operating costs of two motors with their purchase price.

All commonly used swimming pool, spa and jetted tub motors also operate on the principle of centrifugal force.

Pool and spa motors are two pole (3450 RPM) designs. The two speed versions are 3450/1725. Four pole windings are used on the low speed. Theoretically, the loading on these pump motors drop off at a cubed rate compared to the speed. Examples of horsepower ratings are one (1) HP on high speed and one-sixth (1/6) HP on low speed and 2 HP / 1/2 HP.

Pool and spa motors are required to have a ground bonding lug. This lug is on the outside of the motor and when connected offers visual assurance that the motor is grounded. Before doing any work on a pool or jet pump motor, check to see if there is any current leaking to ground.

***Swimming
Pool, Spa and
Jetted Tub
Motors***



**JBT2072
JETTED TUB MOTOR**



SQ1072



SK1072



ST1072



SQ1152



CBS2072

In the past when brass pumps were common, the use of motors with cast iron instead of aluminum end frames was common. The cast iron has less reaction with the brass. Today, most pumps are plastic so this is not a concern.

Small above ground pumps have a sealed motor/pump unit which is not repairable. Motors on the other applications are easily identified by the type of end frame and shaft extension. NEMA 56C face (56C and 56J) and square flange motors are common on in-ground pool pump applications. Many above ground pool pumps and jetted tubs use the motor through bolts to secure the pump to the motor. The motors have a "Y" after the frame designation on the nameplate indicating a non-standard mount. Even though the mount is not standard per NEMA, it has become standard among the pump manufacturers. Spas and jetted tubs may sometimes be similar in looks and construction with the distinction that the water is normally drained from a jetted tub after each use. Spas use NEMA C, square flange and thru bolt mount motors.

Two speed motors are common on single pump spas. High speed is used for the invigorating jet action, and low speed is used to circulate water when the heater is on. Less common is the use of two speed motors on swimming pools. The unit is run on high speed several hours a day for maximum filtration action and then switched to low speed and run continuously. Some filtration action does occur on low speed and a better chemical balance is maintained. Total electrical and chemical consumption may be reduced.

Pool sweep pumps may use motors with special flanges and shaft extensions. These are specifically identified in motor manufacturers' catalogs.

Running a pump dry does not harm the motor which is actually operating at a very light load. However, if the seal is damaged by the dry operating condition, it will leak and probably allow moisture into the motor bearing.

It is not recommended that a jet pump motor be used as a replacement for a pool pump motor even though horsepower and mountings may be equivalent. The pool motor will have a ground bonding lug, different ventilation standards for safety, possibly larger bearings, and a higher ambient temperature rating.

Specifics of motor construction, operation, nameplate information, and servicing are covered in other modules. Following are points which are important to reemphasize in relation to pump motor applications.



**SPS1052
POOL SWEEP MOTOR**



**RPS1052
POOL SWEEP MOTOR**



**PL1072
POOL SWEEP MOTOR**

Voltage

VOLTAGE

Most dual voltage (115/230V) motors are connected at the factory for 230 volts for two reasons. First, the highest percentage of motors are installed on the higher voltage. Second, if a motor is connected for 230 volts and 115 volts are applied in the field, the motor will hum and trip the overload. If connected for 115 volts and 230 volts are applied, it burns out immediately.

Motors are designed to operate at plus or minus 10% of the nameplate rating. This means the motor will operate at 103 volts to 126 volts on the 115 volt connection; and, 207 volts to 253 volts on the 230 volt connection. At 207 volts, the amps will be higher and the RPM will be approximately 25% lower.

If the system is rated at 208 volts or 200 volts, a motor specifically designed for these ratings should be used since the voltage could go as low as 187 or 180. Specific 208 and 200 volt single phase motors are not normally stocked for replacement. The alternative is to use the next higher horsepower motor. For example, use a 1 horsepower, 230 volt motor when a 3/4 horsepower 208 volt motor is needed. Three phase motors have some greater ability to operate at 208 volts. But, the next higher horsepower should be used if a 200 volt motor is required.

NEMA no longer recognizes 208 volt systems. The standard is now 200 volts.

SERVICE FACTOR

Typical service factors for full rated one horsepower pool pump motors are 1.65 for square flange and 1.4 for NEMA C. One horsepower jet pump motors typically have a 1.4 service factor. Over the years, various amp ratings have been used on motor nameplates. Some motors may have rated amps which are amps at one horsepower. This number is basically useless since the impeller loads the motor to the service factor. This motor would also have a rating for full load, service factor or max amps. This is the figure to use when checking a replacement motor after installation. Some service people make a temporary connection so that the amps may be easily checked, or the connections are made so that a loop in the wire is available for checking amps.

If total horsepower or horsepower times service factor is difficult for service persons to understand, the concept is practically impossible to explain to a homeowner. If a one horsepower motor came off the installation, a one horsepower must go back on. Up-rated motors are ones on which the horsepower is increased and the service factor is decreased. The total horsepower remains the same. To see how this works, make a copy of a motor manufacturers full rated and up-rated motor listings. Put the two listings side by side so that the one horsepower up-rated motor lines up with the three quarter horsepower full rated motor. You will see that the characteristics such as amps and weight are the same. The same comparison may be done with pump curves.

***Service
Factor***

The following chart illustrates the important fact of comparing total or maximum horsepower:

High Service Factor Motor				Low Service Factor Motor		
NEMA				Up-Rated		
F.L.	Std. Motor			F.L.	Up-Rated	
HP	SF	MAX HP		HP	SF	MAX HP
1/3	1.75	.58	Uprated →	1/2	1.16	.58
1/2	1.60	.80	Uprated →	3/4	1.07	.80
3/4	1.50	1.13	Uprated →	1	1.13	1.13
1	1.40	1.40	Uprated →	1-1/2	1.00	1.50
1-1/2	1.30	1.95	Uprated →	2	1.00	2.00

High Service Factor Motor				Low Service Factor Motor		
Higher than NEMA S.F.				Up-Rated		
F.L.	Higher than NEMA S.F.			F.L.	Up-Rated	
HP	SF	MAX HP		HP	SF	MAX HP
1/3	1.95	.65	Uprated →	1/2	1.30	.65
1/2	1.90	.95	Uprated →	3/4	1.27	.95
3/4	1.65	1.25	Uprated →	1	1.25	1.25
1	1.65	1.65	Uprated →	1-1/2	1.10	1.65
1-1/2	1.47	2.20	Uprated →	2	1.10	2.20
2	1.30	2.60	Uprated →	2-1/2	1.04	2.60

CAPACITORS

It is recommended that replacement capacitors be of the same MFD and voltage rating as the original. If the exact replacement is not available, it is recommended to use one with a MFD rating not more than 10% greater. Using one with a larger value could make the motor run hot and loose torque. The voltage rating should also vary only on the high side. In some cases, it will be necessary to go beyond 10%. Example, if a 370 volt unit is not available, the next rating is 440 volt.

JET PUMPS

The two most popular types of home water systems have their water delivered and pressure developed by either a jet pump or submersible pump.

As the name implies, the submersible pump/motor unit is located in the water supply and connected to a waterproof electrical supply.

The jet pump/motor unit may be located in the home, or outside if there is little risk of freezing. In freezing areas, the pump may be located outside in a pit which is covered and protected from freezing.

Most jet pumps use open drip proof motors (ODP). When used in a vertical application outdoors, a different or additional rain canopy is required. A separate “dog house” or motor cover such as the Blue Devil™ unit shown here provide protection from the elements and improves motor life. Motor covers must allow free air flow so that hot air from the motor is not recirculated, shortening motor life.

Jet pumps are called single stage if they have one impeller and multi-stage if there are two or more impellers.

The motor shaft is parallel to the ground in a horizontal jet and vertical in a vertical jet.

All jet pump motors are two-pole (3450 RPM) designs.

Jet Pumps

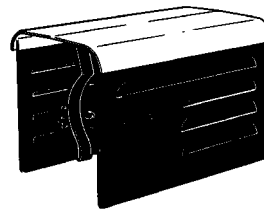

8200 MC-200
UNIVERSAL MOTOR COVER
(fits 1/3 HP to 2 HP motors)



**T1072
JET PUMP MOTOR**

Most jet pumps use NEMA C face (56C or 56J) or square flange motors. Most square flange motors have 1/2-20 threads but some have 7/16-20 threads. Many other centrifugal pump applications such as lawn sprinklers and irrigation use jet pump type motors.

Jet pump motors typically have shielded bearings while swimming pool pump motors have sealed bearings. Both types of bearings are permanently lubricated and neither is waterproof.

Running a pump dry does not harm the motor which is actually operating at a very light load. However, if the seal is damaged by the dry operating condition, it will leak and probably allow moisture into the motor bearing.

Jet pumps operate on the principle of centrifugal force. The motor spins the impeller which does the work.

Jet pumps get their names from the principle of operation in which a stream of water is pushed through a nozzle into a diffuser creating an area of low pressure. This low pressure draws additional water from the supply (usually a well).

The action of getting water from the well into the pump system is caused by air pressure. At sea level, air has enough pressure to lift a column of water thirty-four (34) feet. Because of differences in air pressure, elevation and system efficiencies, most jet pumps have an arbitrary lift rating of twenty-five (25) feet.

One way of visualizing the action is comparing it to drinking from a straw. The partial vacuum created when you suck on the straw causes the drink to be forced up the straw by air pressure. If the container from which you were attempting to drink were sealed, liquid would not be drawn into and up the straw.

Jet pump systems may be shallow well or deep well. In shallow well systems the jet assembly is located on the pump. In deep well systems the jet assembly is located in the well, normally below water level. If the water level falls more than twenty-five feet below the jet during pumping or draw down, the pumping action will slow and eventually stop as the water level in the well continues to drop.

Convertible jet pumps may be configured for either shallow or deep well applications.

Shallow well systems use one pipe into the water source and deep well systems use two pipes. One pipe provides water to operate the jet and the second pipe carries water to the surface. Systems known as packers are deep well systems which use the well casing itself as one of the two pipes.

A pitless adapter is a fitting which goes through the well casing below the frost line. The part inside the well has two pieces, with an O-ring seal, which slide apart. A piece of pipe is threaded into the top of the adapter so that the movable part and the pipe or pipes extending to the water may be removed. The use of a pitless adapter allows the pipe or pipes going to the pump to be buried below the frost line.

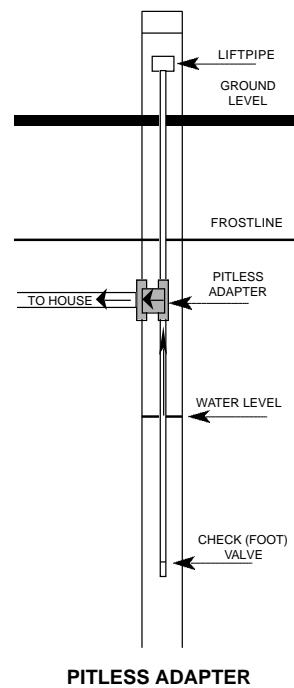

**DIAPHRAGM
PRESSURE TANK
30 PSI CUT IN
50 PSI CUT OUT**

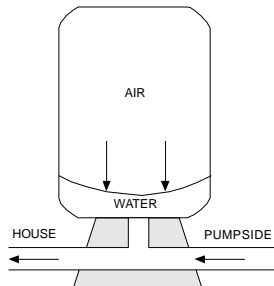
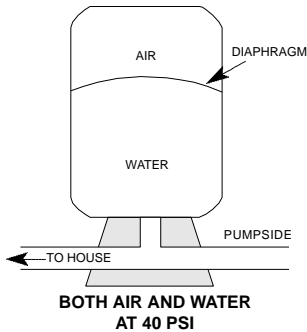

1. FAUCET OPENED
2. AIR PUSHES ON DIAPHRAGM
3. WATER SENT TO SYSTEM
4. AT 30 PSI, PUMP STARTS

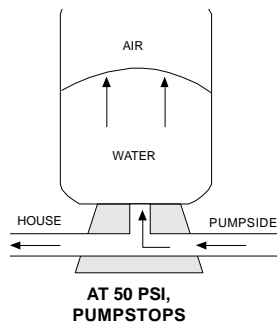

A check valve or foot valve is normally located in the plumbing line before the pump. This “one way” valve is needed so that the pressure in the system will not bleed off when the pump stops. If the valve leaks, the pump will start and stop, even though water is not being used.

Since for all practical purposes, water is non compressible, a pressure tank is used in the system.

A pressure switch is used to start and stop the motor. The “cut in” setting is the pressure at which the motor starts. The “cut out” setting is the pressure at which the motor stops. The amount of water (in gallons) that is pumped in each cycle is called draw down. In a specific system, the draw down amount may be varied by changing the cut in and/or cut out settings.

The low and high pressures of the system are determined by the cut in and cut out settings, not by the amount of air pressure in the system.

As water is pumped, air in the tank is compressed until system pressure reaches the cut out level. The most popular tanks have a bladder or diaphragm which separates the air and water. Other systems use an air volume control and put air into the tank each time the pump is started. If the water and air were not separated, or air was not added, the air in the tank would all dissolve in the water and the tank would become “waterlogged”.

If the air charge in a system is reduced, the pump will still start and stop at the same pressures, but less water will be pumped in each cycle because there is less air to compress. As the amount of air is decreased, the tank approaches a waterlog condition and the system operates as if there were no pressure tank.

The primary function of the pressure tank is to protect the pump motor. Without a tank, pressure in the system would drop to zero almost immediately when a faucet was opened. Then, almost as quickly, the cut out pressure would be reached and the pump would shut off. The cycle would repeat as long as the faucet remained open. This is the same thing that happens when a pressure tank becomes waterlogged.

Short or rapid cycling is hard on the pump motor whose windings are subjected to starting or in rush current levels on an almost constant basis. The start capacitor will often fail because its duty cycle is exceeded. They are rated at twenty starts of three second duration per hour. Rapid cycling causes heat to build up which may cause failure. Premature wear also occurs on the start switch.

When a pump's flow decreases, the pressure increases to a point known as shut off. This pressure may be many times the cut out pressure setting. Water hammer is caused by flowing water in a system suddenly being stopped. Water hammer can cause sudden pressures as high as 760 PSI with system pressure of only 60 PSI. Since there is a delay between the time the pressure switch senses cut out and the time the pump actually stops, water hammer will occur.

The shut off point may be determined by a gauge with the pump running against a closed discharge. This point could also be found by lengthening a vertical discharge pipe to the point where the pump is unable to cause water to flow from the top.

When running at shut off the energy is converted to heat. The water in the pump casing can boil under pressure to the point where a plastic impeller is melted. Some of the heat goes into the motor shaft and back to the bearing causing possible failure.

If a jet pump is used as a centrifugal pump with the jet assembly removed, the motor may overload particularly in a flooded suction condition. Flooded suction means water is available to the pump without the pump having to create a suction lift.

Jet pump motors may be either single voltage (115 or 230 for example) or dual voltage (115/230). On original equipment, 115 volt 1/3 and 1/2 HP units are common since there is enough volume to warrant a separate model with a slightly lower motor cost. Most replacement motors are dual voltage and factory connected for high voltage. If 115 volts are applied to a motor connected for 230 volts, the motor will just hum and probably not turn. In the reverse condition, the motor will immediately burn out.

The motor will not run faster or be more efficient on the high voltage, but a smaller wire size may be used since the amps at 230 volts are one-half the amps at 115 volts.

A dual voltage motor is sometimes temporarily run on low voltage at a new home site until the permanent power supply is available.

Motor Troubleshooting Guide

There is not a single listing of motor troubleshooting procedures to be followed in a given order. The procedures will also differ for new and existing installations, and motors that are being bench checked. As with anything dealing with electricity, personal safety is the prime concern.

Checking a motor in its application is the only practical method for most people to determine performance under load. If the motor is defective, the application provides many clues to help determine the cause. Did the motor fail due to a defect or old age, or was its failure hastened by the application or environment? The application is the only place an attempt may be made to check voltage.

On permanently installed equipment, the voltage may vary depending upon the total system load. It can also vary with the total load on the power company grid.

While some of the troubleshooting procedures that follow apply specifically to the two compartment A.O. Smith pump motor, the basics apply to other motors.

WARNING!

This is not a guide for the do-it-yourselfer. These tips and suggestions are offered for persons with proper qualifications and necessary test equipment.

See that this electrical list is followed:

- Assure proper voltage at motor terminals.
- Follow motor connection diagram on motor nameplate.
- Make sure motor is properly GROUNDED and complies with local and national electrical codes.
- See that the pump turns freely before starting motor.

**FAILURE TO START
(MOTOR MAKES NO SOUND)**

- Check voltage at motor line terminals. Voltage should correspond with motor nameplate rating ($\pm 10\%$).
- Check all electrical connections at the motor terminal board.
- If no voltage is present; check fuses, timers & switches.
- Protector tripped — wait until motor cools then restart — check protector for continuity.



The following chart shows recommended minimum wire sizes for pump motors. The calculations were based on motors with the highest starting currents. Larger wire sizes reduce the voltage drop at the motor in both the start and run modes. A lower voltage drop means the motor will run more efficiently (cooler) and have increased service life. In general, and up to a certain point, the efficiency gained from one size larger wire will have a payback of less than two years.

PUMP MOTOR RECOMMENDED MINIMUM WIRE SIZE*

Motor H.P.**	DISTANCE FROM SERVICE ENTRANCE/MAIN PANEL TO MOTOR							
	50 feet		100 feet		150 feet		200 feet	
	115V	230V	115V	230V	115V	230V	115V	230V
1/3	14	14	12	14	10	12	8	12
1/2	14	14	10	14	8	12	8	10
3/4	12	14	10	12	8	12	6	10
1	12	14	8	12	8	10	6	8
1-1/2	10	14	8	12	6	10	6	8
2	10	14	8	10	6	10	6	8
3		12		10		8		8

*Always follow all applicable codes.

**Pump Motors with service factors greater than 1, and split phase designs. No more than 15 volts drop at start, in worst case.

**FAILURE TO START
(MOTOR HUMS OR ATTEMPTS TO START)**

- Check voltage at motor line terminals. If voltage is inadequate to start motor, check for loose connections, undersized wiring, overloaded circuit or other causes of voltage drop.
- Start switch contacts not closed when motor is not operating. Switch may require adjustment. Switch contacts dirty or pitted.
- Capacitor (where used) is “shorted” or “open”.
- Check motor windings for “open” or “short”.
- Check for continuity through protector.
- Turn the motor shaft by hand to get the “feel” of the motor. If the shaft feels tight or doesn’t turn smoothly:
 - Check the bearings for smooth operation.
 - See if there is evidence of the rotor striking the stator.
 - Check for internal corrosion, cracked end frames, clogged fan or other obstruction within the motor.
 - Check pump for obstructions, binding impeller, or bent shaft.

OVERHEATING

As in all motor applications, excess heat is very detrimental to motor operation and life. Heat over time breaks down motor insulation and leads to failure. The relationship of temperature to life is geometric. In other words, as the temperature goes up the winding life is shortened at an increasing rate.

A continuously running pump motor may be hot to the touch and this by itself does not mean the motor is overheating.

Excess heat has many possible causes:

- Low voltage. The voltage may be low at the source or there may be excessive voltage drop when the load is applied due to too small a wire size.

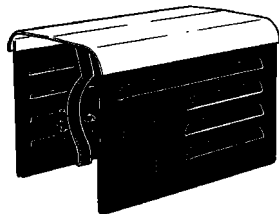

8200 MC-200
UNIVERSAL MOTOR COVER
 (fits 1/3 HP to 2 HP motors)

- **Overvoltage.** This needs correction by the power company.
- **High ambient temperature.** Pool motors are normally designed to operate in higher ambients (50°C) than jet pump motor which usually have short duty cycles. Artificially high ambients may be created if the motor operates in a confined space and recirculates the air.
- **Protect the motor from excess heat by shading from the sun with a motor cover such as the Blue Devil™ unit illustrated here.** It is important that a motor cover provides fresh air circulation and does not allow air heated by the motor to recirculate.
- **Reduced air flow.** Foreign material such as grass clippings, leaves, lint and bugs and small lizards may plug air passages.
- **If the motor has an internal cooling fan, is it intact and functioning properly?**
- **Application overload.** In cases of flooded suction or positive pressure on the inlet to the pump, flow may be increased, overloading the motor.
- **Misapplication.** Specific motor and impeller combinations are sized to do a specific job. In most cases, the impeller loads the motor to the service factor horsepower. It is absolutely imperative that a replacement motor is able to develop the same or higher total horsepower (nameplate horsepower X service factor) as the motor being replaced.
- **Compare the running amperage of the motor with MAXIMUM LOAD or SF amps.** If amperage is higher than MAXIMUM LOAD or SF amps, with proper voltage applied, determine cause of overload.

- Check motor windings and capacitor (where used) for “ground” or “short”.
- Check terminal board connections with the motor wiring diagram for proper applied voltage.
- Check the motor start switch and governor to be sure it is adjusted properly and is operational.

NOISY OPERATION

- Check motor coupling, brackets and other attached parts for adjustment or looseness.
- Motor bearings.
- Pump cavitation.

ELECTRICAL SHOCK

- Check motor windings, all motor wiring, and capacitor for ground.

PROTECT AGAINST MOISTURE

- The open drip proof type motors discussed here may be used outside, but their life expectancy is enhanced if they are protected from the elements. The enclosures should not restrict air flow or cause recirculation.
- Motors that are out of service, such as pool motors in the winter, should not be sealed in plastic bags which cause condensation directly in the motor.
- If the motor is not running it may be covered for short periods of time such as when the area around a swimming pool pump is being hosed down.

- Locate motor on a slight elevation so water will not run or puddle nearby.
- Avoid spilling or dripping liquid chemicals on or near the motor.
- Avoid splashing water on or near the motor.
- Repair leaky pipe joints, “O” rings, or pump seals promptly.
- Avoid locating motor in highest humidity area.

If the motor is flooded, the bearings may be ruined. Once they start making noise, failure is imminent.

If the seal leaks and is not replaced, the bearings may also be ruined. A new seal should be installed any time a motor is replaced. A slinger or flinger should also be used on the motor shaft to deflect water from the bearing location.

PROTECT AGAINST DIRT & CHEMICALS

- Avoid sweeping or stirring dust near the motor while it is running.
- Chemicals should not be stored near the motor. Chlorine can be especially damaging if in a liquid form being dispensed into a filter pit.

ELECTRICAL CHECKS

The next section explains the use of test equipment.

CONVENTIONAL MULTIMETER OR OHMMETER

An ohmmeter can be used to measure the resistance of the various motor windings as well as to test the insulation.

The ohmmeter will have numerous ranges from R x 1 where the meter reads directly in ohms to an Rx100K where the actual meter reading must be multiplied by 100,000 for the actual ohm value.

Before using an ohmmeter:

- Make sure all motor leads are disconnected from the power source.
- Make sure the meter is adjusted to zero before taking each reading.
- All troubleshooting checks specify the ohmmeter range to be used. If your meter does not have the exact range, use the next higher range.

DIGITAL OHMMETER/MULTIMETER

Direct reading digital ohmmeters are readily available in the field. To use this type:

- Make sure all motor leads are disconnected from the power source.
- Read instruction manual for the meter.
- You do not have to set the ohmmeter to a particular scale as the meter displays the ohm value up to the maximum capability of the meter.
- Install probes and take resistance readings in the normal manner.

AMMETER AND VOLTMETER

Voltmeter Readings:

Install leads in bottom of Amprobe®. Select the desired voltage scale. Take readings by touching one probe to each of the lead line terminals.

Ammeter Readings:

- Arrange leads so the jaws of the Amprobe® will encircle one lead.
- Set meter on maximum amp scale and encircle jaws around one lead and take reading. It may be necessary to reset to a lower scale.

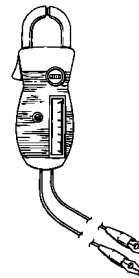

VOLTAGE CHECK

- Disconnect power source
- Remove canopy
- Determine motor voltage and set meter on proper scale
- Reconnect power
- Start motor

Touch one probe to L1 and the other to L2. Voltage reading to be within 10% of nameplate voltage, i.e. between 207 and 253 volts for a 230 volt motor.

If no voltage is recorded, check pressure switch, fuses, circuit breakers, timers, wiring, etc. for open connection or broken wires.

If voltage is outside the acceptable limits-check for adequate wire size. Look for loose terminals and connections, or pitted contacts, check pressure switch and pump disconnect switch.

Check voltage at service entrance. If not within $\pm 10\%$ contact power company.

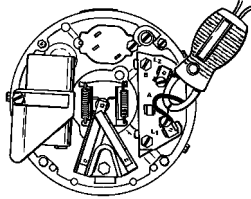
**AMPERAGE CHECK**

- Turn off power at pump disconnect switch.
- Set ammeter scale based on max. load amps.
- Position one line lead (L1 or L2) so that jaws of amprobe can encircle one power lead.
- Make sure switch and governor are free of obstructions.
- Reconnect power.
- Start motor.
- Encircle one line lead with jaws of amprobe and take reading. This value should not exceed maximum load amps of motor.

Excessive amps means an overloaded condition or incorrect voltage applied. Problem could also be in motor.

START SWITCH CHECK

- Visual checks:
 - Disconnect power source.
 - Remove canopy.
- Make sure there are no obstructions preventing the proper operation of the rotating governor. Check wiring and make sure none of the leads are in the area of the governor where they can be cut or interfere with the governor. Check governor for proper operation and make sure flipper is free to move.
- Check switch contacts for severely burned or pitted contacts, sticking etc. Some blackening or pitting is normal after motor has been used. Replace switch if there is any doubt. Don't try to repair by bending the contact leaf.
- Unlike points in an automotive distributor, the switch contacts in motors are plated and should never be sanded which would remove the plating and cause early failure. They may be cleaned by wiping with a piece of cardboard or paper bag.
- Reconnect power.
- Start motor. Visually check the action of the switch and governor. Switch contacts must be closed when motor is at rest and should open when motor reaches about 2/3 of full load speed.

NOTE: Replace capacitor and switch at the same time. A defective switch usually stresses the start capacitor.

START SWITCH ADJUSTMENT

- Fasten switch snugly to end bell, through "U" bracket with the screw provided.
- A slight amount of switch movement is possible before the screw(s) is tightened. Check to see that the white switch button is centered over the governor projection.
- Reach in and move the governor weight (overcoming the spring tension) until it touches the stops on the governor.
 - The clearance between the projection and the white button should be .010" to .040" (.040 is about the thickness of paper clip wire).

- Most newer models use only one screw to secure and adjust the switch. When a new switch is installed, or an existing switch is being reinstalled, the "U" bracket should be opened slightly to insure sufficient tension against the screw. Tighten only when adjusting. If the screw is loosened, it should be removed and the "U" bracket should again be opened slightly.
- On models with two screws, turn the switch adjustment screw until the correct clearance is obtained. When finished, tighten the adjacent switch screw to secure the switch to the bracket.
- Under no circumstances should switch contact leaves be bent or deformed in an attempt to obtain proper contact clearance.

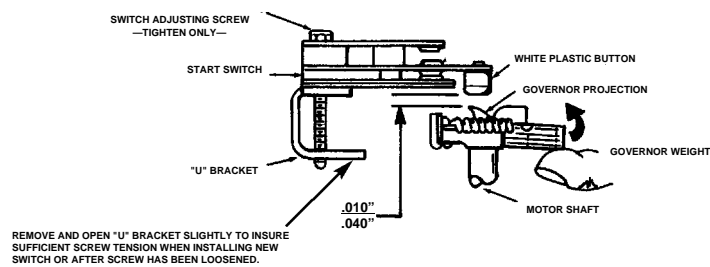

MOTOR COMPONENT CHECKS

Based on your observations perform the following checks to confirm that each component is functioning properly.

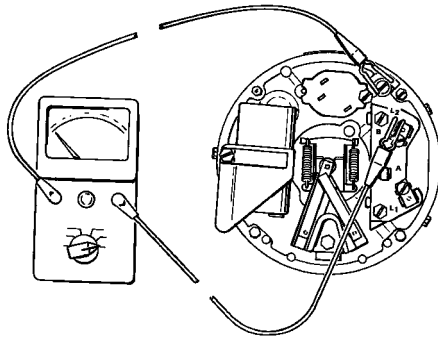
**GROUND CHECK**

Ground Check — Set ohmmeter to R x 1K.

- Attach one probe to ground screw and touch other probe to all terminals on terminal board, switch, capacitor and protector. A reading of less than 10K could indicate a ground. New motors typically read over one megohm. Old motors with dust, dirt and moisture could show resistance to ground below 10K and still run satisfactorily. A cleaning may be in order. Readings may vary from day to day depending upon the humidity levels. Approximately 25K at 115 volts will trip a ground fault device. Keep in mind the ground fault device is seeing the total leakage of all loads on the circuit. GFI's normally trip on readings from 4 to 6 milliamps.
- If grounded, check all external leads for cuts, breaks, frayed wires, etc. Replace damaged leads and recheck for grounds and proper lead routings. Make sure replaced leads are not pinched between canopy and end bell. If ground is in stator, replacement of motor is recommended.

WINDING CONTINUITY

(For typical single phase, dual voltage only, capacitor start, single speed motor, connected for 230V. Set meter to R x 1).

For single voltage motors, check between L1 and L2.

Slip a heavy piece of paper between points, taking care not to bend tabs. Discharge capacitor by shorting across the terminals with the blade of an insulated screwdriver. Take the following ohm readings.

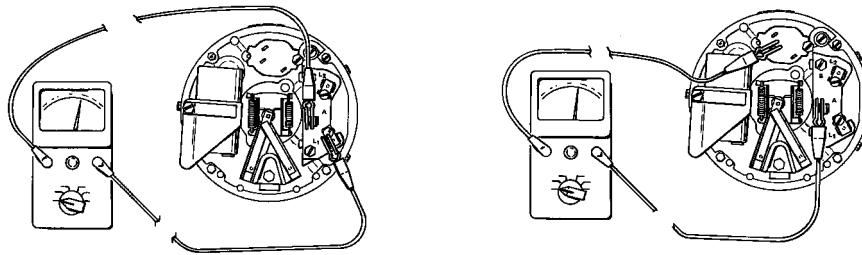

Resistance between L1 and A must be same as between A and yellow.

YELLOW TO RED

L₁ TO RED

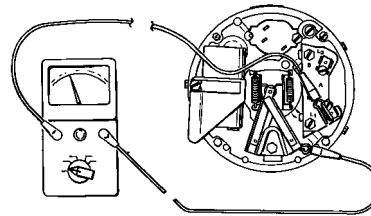

Yellow to red (winding side of switch) must be same as L1 to same red terminal.

CAPACITOR

Capacitor — Set ohmmeter at R x 1K.

Slip a heavy piece of paper between points.

Discharge capacitor by touching the two terminals with the blade of an insulated handle screwdriver.

- Attach one probe to each terminal; ohmmeter needle should move rapidly to right then slowly drift to the left. (Low ohm reading to high ohm value).
- If a digital meter is used, readings should start low and rapidly increase to maximum value.
- Replace capacitor if bad.

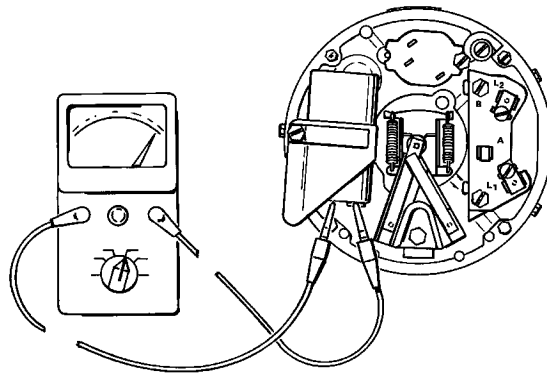
**SWITCH**

Remove paper and attach one lead to each switch terminal. Ohmmeter reading should be 0. Flip governor weight to running position. Reading should be infinity.

NOTE: Motor cycling on overload indicates some other problem, not just a defective overload.

PROTECTOR (THERMAL OVERLOAD)

Protector — Set ohmmeter to R x 1.
Resistance between protector terminals:
1 & 2 should be approximately 0 (Disc).
2 & 3 should be approximately 0 (Heater).
Replace if either value exceeds 1 ohm.

1 & 2

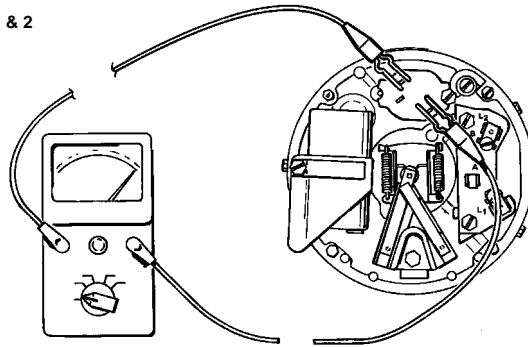

PUMP DISASSEMBLY

Wrench flats on shaft have been provided to facilitate impeller removal. Insert a 7/16" open end wrench under governor assembly and hold while unscrewing impeller. (NOTE: For easier access, the capacitor can be removed from its mounting bosses).

NOTE: If necessary to remove motor from pump, disassemble pump in accordance with pump manufacturer's recommendation.

* Motors produced since 2000, have an improved wrench access area behind the overload.

SINGLE SPEED MOTOR — TYPICAL SCHEMATIC DIAGRAMS
 Capacitor Start
 Induction Run — Single Speed

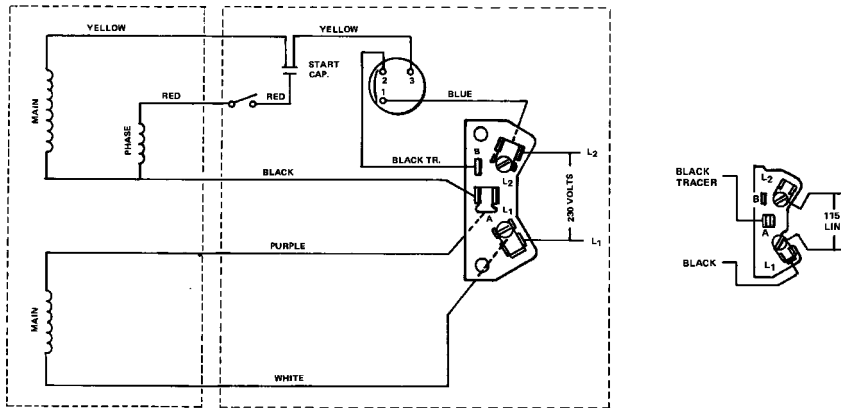

EXT. & WIRE ROUTING
 Dual Voltage — Single Speed — Capacitor Start
 With Voltage Change Plug

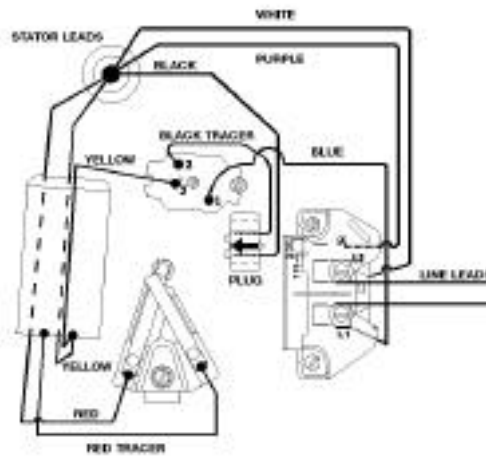

Capacitor Start
Capacitor Run — Single Speed

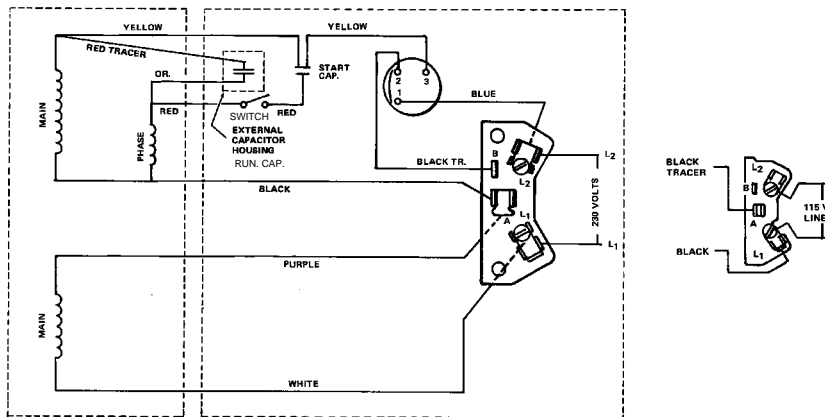

SINGLE SPEED MOTOR — TYPICAL SCHEMATIC DIAGRAMS
Capacitor Start* or Split Phase
Single Voltage on Winding Protector

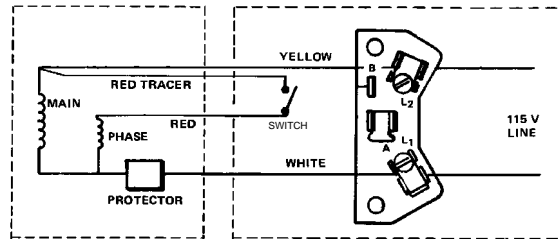

*Capacitor not shown in schematic.

MOTOR ASSEMBLY

All of the motors covered by this manual are similar in design and construction, with variations in baffles, type of protector, type of flange, and bearing construction. When disassembling, make sure you note the exact location of all components so they can be reassembled in the proper order. This is especially true of the bearing assembly where the number and types of small parts (rings, washers, etc.) varies substantially from model to model.

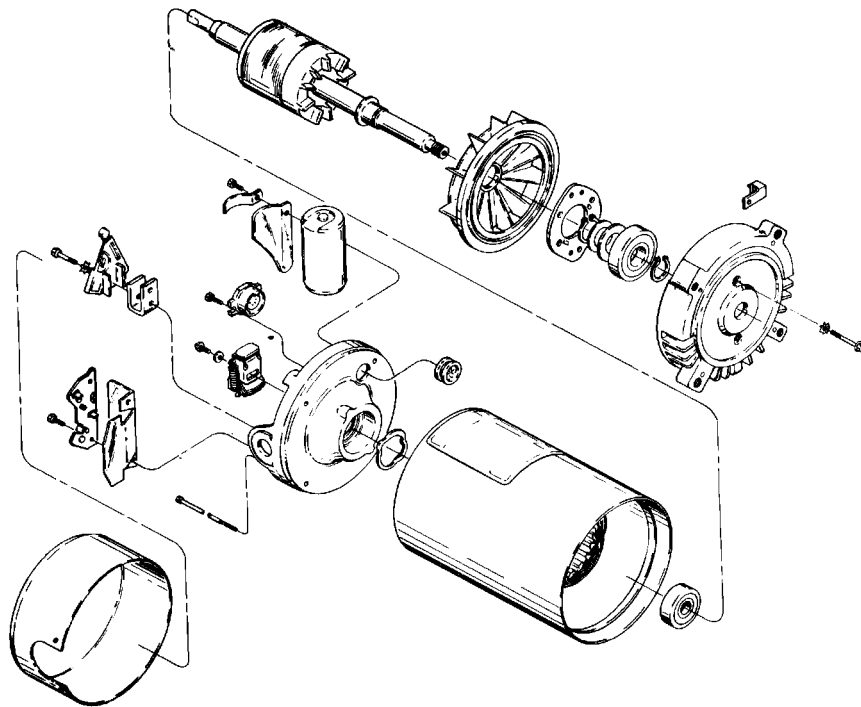

HOW TO REPLACE BEARINGS

1. Remove the bearing(s) from the motor shaft following these steps as necessary:

- Use an external ring pliers to remove snap rings which are used to secure bearings.
- Use a bearing puller to remove defective bearing(s). Don't reuse a bearing which has been removed from the shaft.
- Remove miscellaneous small parts (washers, etc.) from shaft after bearings are removed. Be sure to replace in proper order.

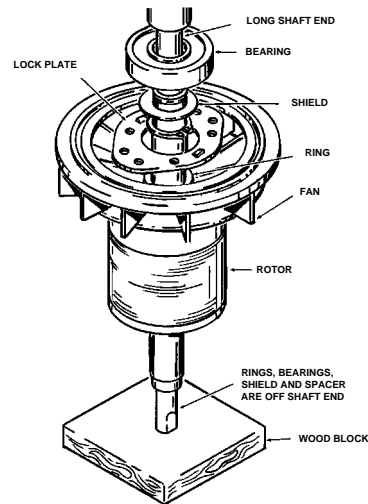

2. Install the new bearing(s) using the motor illustration and typical bearing installation view as an assembly guide. Follow these steps as necessary.

- Refer to the table for the size tube needed to install new bearing(s). It is important to press only on the bearing inner race. The bearing will be damaged if the outer race surface is used for pressing.
- Fan end: Place the short end of the shaft on the wood block. Place the bearing (and other parts as used) over the long end of the shaft. Tap the bearing into place using the proper size tube and a mallet, or use a press. Attach any parts (as used) to the long shaft end.

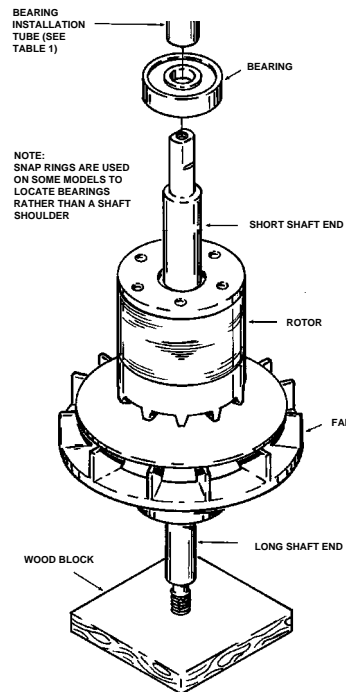

- **Opposite end:** Place the long end of the shaft on the wood block. Place the bearing (and other parts as used, such as snap rings and washers) over the short end of the shaft. Tap the bearing into place using the proper size tube and a mallet, or use a press. Attach any other parts (as used) to the short shaft end.

Compare the rotor and shaft parts assembly shown on the previous pages with the order of assembly found on the motor during teardown. The miscellaneous parts (washers, snap rings, etc.) vary from motor to motor, so when disassembling use care to identify these parts and their order so they can be reassembled in the proper sequence.

BEARING INFORMATION TABLE

Bearing Size	Bearing Dimensions			A.O. Smith Bearing Part No. ¹	Bearing Installation Tube Dimensions (In Inches) ²		
	Diameter (Inches)		Width (Inches)		Outer Diameter of Tube	Wall Thickness	Minimum Length
	Inside	Outside					
202-16	.6299	1.3780	.4331	610358-1	7/8	.095	3
203	.6693	1.5750	.470	604005-4			
204	.7874	1.8504	.5512	600269-2	1	.095	3
304	.7874	2.0472	.5906	603628-2			
205	.9843	2.0472	.5706	612096-1	1-1/4	.125	3

1. Only use bearings obtained from A.O.Smith and ordered by the proper A.O.Smith part number. Do not substitute other bearings, or reuse bearings which have been pulled from shafts. Bearings obtained from A.O.Smith are built with balls having a specific fit, checked for sound level and filled with high grade grease for the temperature and service conditions.
2. Replacement instructions show how the bearing installation tube is used to install new bearings.

RECOMMENDED TOOLS

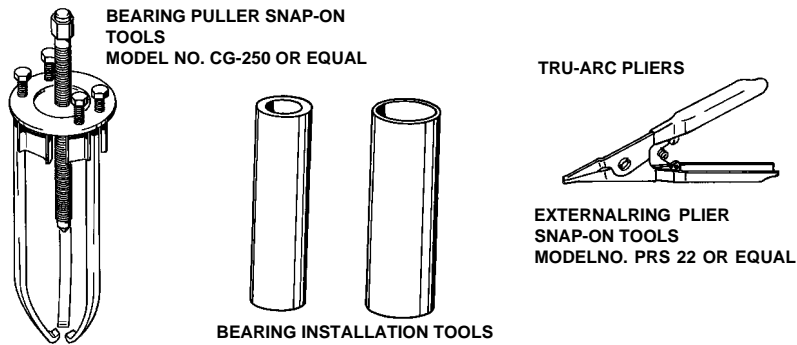

CAUTION: When routing leads under the canopy be sure that:

- A. No leads are in the area of the rotating governor.
- B. When the canopy is installed make sure leads will not be pinched between the canopy and the end frame.

NOTE: In either case the fault could cause a ground, resulting in a very dangerous condition should power be applied without proper grounding.

MOTOR REASSEMBLY

Reassemble the motor in reverse of the disassembly procedure.

- Observe all reassembly precautions and adjust the motor start switch.
- Recheck wiring.
- Check rotor and shaft and make sure it turns freely by hand.
- Check motor for grounds before applying power.

2-SPEED MOTORS

Two-speed motors are regulated by various types of controls which range from a simple “high-low” toggle switch to elaborate and exotic automatic systems. Thus troubleshooting two-speed systems requires an extensive knowledge of both motors and controls.

Two-speed motors are built with and without high-low switches. The conversion of a “with” switch motor to “remote” switch operation requires more than just removing the switch. Schematic diagrams are included in this section for conversion purposes.

Capacitor start — Motors of this design have a model number beginning with C (i.e., C48 or C56) and usually start on the high speed (2-pole) winding.

Split phase — a split phase motor (S48) always starts on high speed. There is no start capacitor, therefore, the red tracer lead from the start winding connects directly to terminal #2 on the switch.

Capacitor start and run — motors of this design have a model number beginning with K (i.e., K48 or K56) and will have a run capacitor mounted on the exterior of the motor.

Thermal protector — 2-speed motors always have the thermal protector located on the motor windings.

START SWITCH REPLACEMENT AND ADJUSTMENT — 2-SPEED MOTORS

Proper starting switch adjustment on two-speed motors is essential for satisfactory operation and contact life.

- Disconnect all power to the motor before attempting any repair. Repair work should only be performed by a qualified electric motor technician.
- Fasten switch snugly to end bell, through "U" bracket with the switch mounting screw provided.
- A slight amount of switch movement is possible before the screw(s) is tightened. Check to see that the white switch button is centered over the governor projection.
- Lift the governor weight (overcoming spring tension) until it touches the stops on the governor. Clearance between the governor projection and white button should be .010" to .040".
- Most newer models use only one screw to secure and adjust the switch. When a new switch is installed, or an existing switch is being reinstalled, the "U" bracket should be opened slightly to insure sufficient tension against the screw. Tighten only when adjusting. If the screw is loosened, it should be removed and the "U" bracket should again be opened slightly.
- Under no circumstances should switch contact leafs be bent or deformed in an attempt to obtain proper contact clearance.
- Once the governor weight is released, and the governor projection pushes on the switch button, contact Z should move away from the motor by approximately .030". This movement assures that the points will have sufficient contact no matter what position the rotor/shaft and governor projection are in at rest.

In run position contacts X & Y must be open and contact Z closed. At rest, contacts X & Y must be closed and contact Z open.

SWITCH ADJUSTMENT

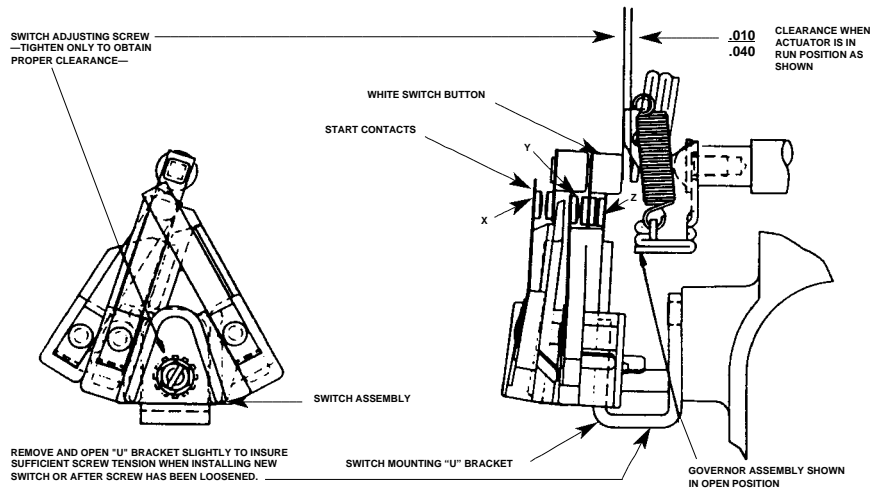

SWITCH CONNECTIONS — HIGH SPEED START

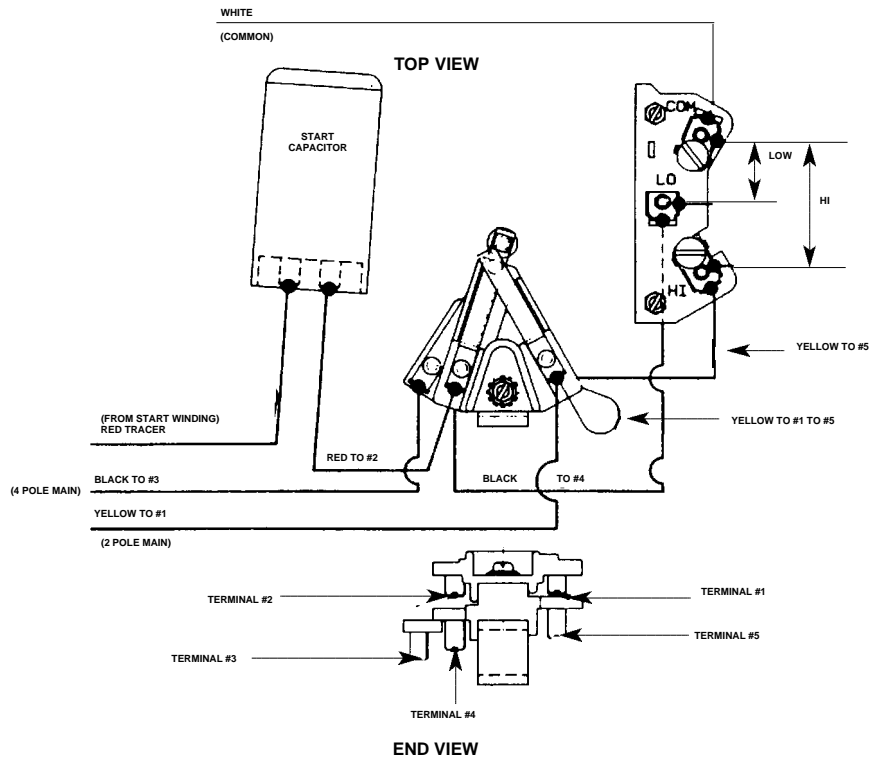

SWITCH CONNECTIONS — LOW SPEED START

Low speed start — this design motor always starts on the low speed (4-pole) windings. When the control calls for high speed run, the start switch automatically switches the motor to high.

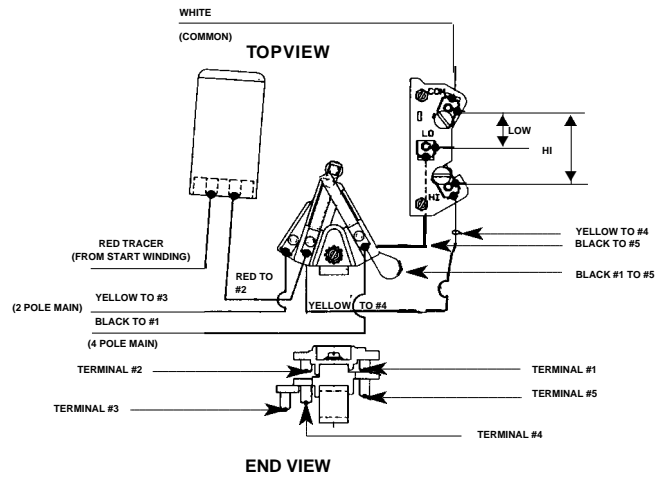

**2-SPEED MOTORS — HIGH SPEED START
SCHEMATIC DIAGRAM**
2-Speed for Remote Switch Operation

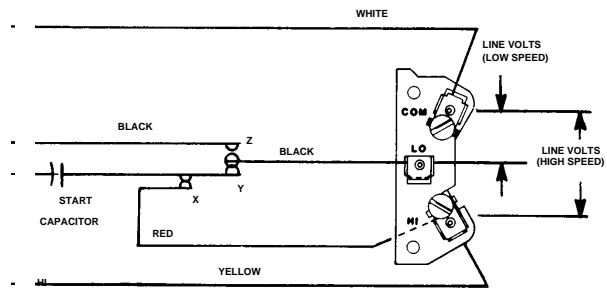

START - X & Y CLOSED Z
OPEN
RUN - X & Y OPEN Z CLOSED

**2-SPEED MOTORS — HIGH SPEED START SCHEMATIC
DIAGRAMS AND RECONNECTION INSTRUCTIONS FOR
REMOTE OPERATION**
2-Speed with Hi - Low Switch
Mounted on Motor Canopy

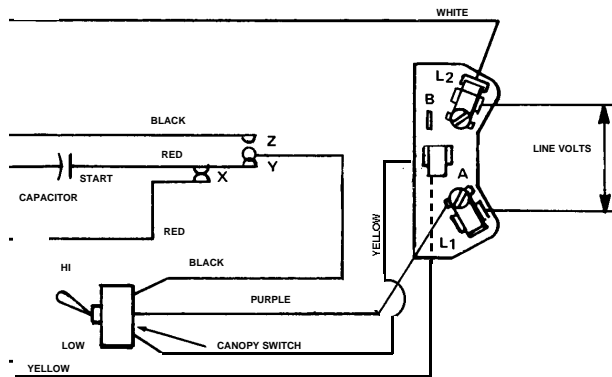

YELLOW MUST BE CONNECTED TO BOTTOM TERMINAL WITH SWITCH IN POSITION SHOWN

START - X & Y CLOSED Z OPEN
RUN - X & Y OPEN Z CLOSED

NOTE: Several different connections have been used in production. If the wiring on the motor you are reconnecting does not match these diagrams contact A.O. Smith and we will FAX or mail a connection for that model.

RECONNECTION FOR REMOTE SWITCH OPERATION

REMOVE BOTH YELLOW LEADS FROM 'A' TERMINAL AND CONNECT TO TERMINAL L1.

REMOVE BLACK LEAD FROM HI-LOW SWITCH AND CONNECT IT TO TERMINAL A.

LEAVE SWITCH IN CANOPY AND LEAVE PURPLE LEAD CONNECTED TO SWITCH.

CONNECT POWER SUPPLY LINES TO TERMINAL BOARD
L2-L1 HIGH SPEED
L2-A LOW SPEED

BEFORE REPLACING MOTOR CANOPY, BE SURE ALL LEADS ARE PROPERLY PLACED TO PREVENT DAMAGE FROM GOVERNOR AND/OR CANOPY.

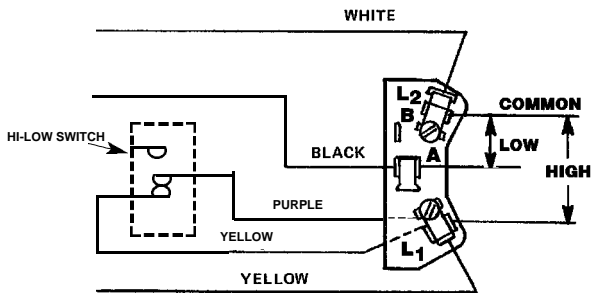

**2-SPEED MOTORS — HIGH SPEED START SCHEMATIC
DIAGRAMS AND RECONNECTION INSTRUCTIONS FOR
REMOTE OPERATION
2-Speed with Hi - Low Switch
Mounted in External Box**

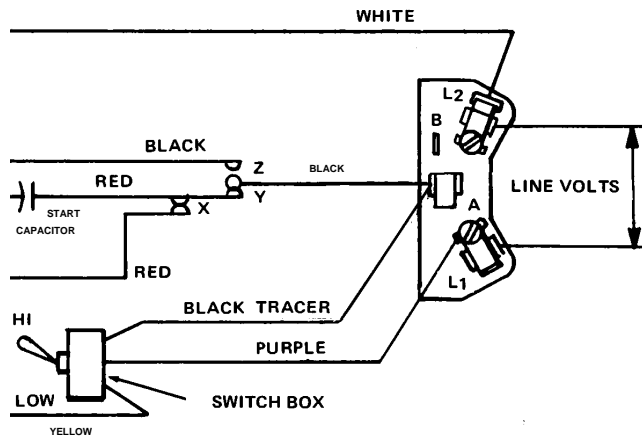

NOTE: Several different connections have been used in production. If the wiring on the motor you are reconnecting does not match these diagrams contact A.O. Smith and we will FAX or mail a connection for that model.

RECONNECTION FOR REMOTE SWITCH OPERATION

DISCONNECT PURPLE AND YELLOW LEADS FROM HI-LOW SWITCH AND CONNECT TOGETHER.

DISCONNECT BLACK TRACER LEAD FROM HI-LOW SWITCH PERMANENTLY. TAPE UPEXPOSED END.

CONNECT POWER SUPPLY LINES TO TERMINALBOARD
L2-L1 HIGH SPEED
L2-A LOW SPEED

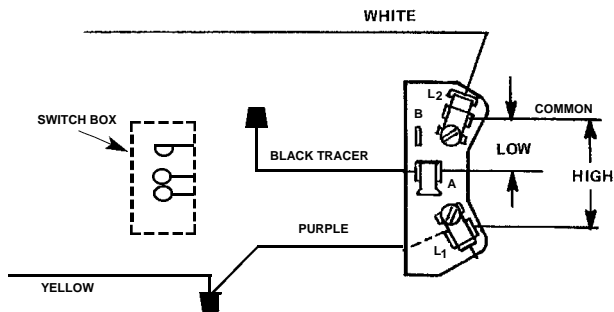

MOTOR REPLACEMENT REMINDERS

- A. If possible, isolate the cause of failure so that:
1. There will be confidence that a similar replacement motor will have an acceptable service life.
 2. If external conditions (moisture, low voltage, etc.) contributed to the failure, they may be corrected.
- B. Match the mechanical and electrical characteristics of the original and replacement motors.
1. **Mounting**
This will include the end frame, shaft extension and base (if so equipped). The nameplate will provide some or all of the needed information in the section for frame size (FR).
 2. **Electrical**
Determine operating voltage, phase, max amps and hertz or cycles.
 3. **Horsepower**
Multiply nameplate horsepower times the service factor to find total horsepower. The total horsepower of the replacement motor must equal or exceed the original motor.
 4. **Model Number**
Each motor has a series of numbers and/or letters which designate one specific design. This number alone is sufficient for the manufacturer to cross reference the motor for replacement. If this number was crossed previously, it may be on a published list. Don't rely on the number alone. A difference of one number or letter means a different motor. The model number may contain some descriptive information, but by itself does not enable someone in the field to select a replacement.

***Motor
Replacement
Reminders***

It may even lead to confusion. For example, some A.O. Smith pump motor model numbers begin with a letter: C = Capacitor Start, S = Split Phase, K = Capacitor Start and Run, P = Polyphase. The next two numbers designate the motor frame size: 48 = 48 Frame, 56 = 56 Frame. The next letter designates horsepower: J = 1/2, K = 3/4, L = 1, etc. The frame in the model number refers to the motor's diameter of 5-5/8", not the NEMA frame designation which may be 56C or 56J, etc. The horsepower letter designation is useless without the service factor.

If the nameplate is not legible, it will be necessary to utilize pump data and system voltage in order to select a replacement.

- C. Always install a new seal when reassembling a pump or installing a replacement motor.
- D. Be sure the motor is connected for the system voltage. Most A.O. Smith dual voltage pump motors are factory connected for the higher voltage for two reasons. First, lower current draw on high voltage allows the use of smaller circuit wire, and reduces light flicker or dimming when the motor starts. Second, if a motor is connected for high voltage and low voltage is applied, the motor will just hum, or start and run very slowly until it trips the overload. If a motor is connected for low voltage and high voltage is applied, the motor burns out immediately.
- E. Always be sure the motor is properly grounded before applying power.
- F. Use an ammeter to assure that the motor is not overloaded. The max load or SF (service factor) amps on the nameplate should not be exceeded.

OPERATING REMINDERS

- A. Locate the pump/motor in a clean, dust-free area. Most pool and jet pump motors are open drip proof designs which circulate external air for cooling. Air contaminants such as sweeping dust and grass clippings may clog internal air passages leading to overheating.
- B. Protect from excess moisture. Don't hose down the area around the motor when it is running. Elevate the pump/motor if it is in an area that is prone to flooding.
- C. If an external motor cover is used, be certain it does not trap moisture or allow cooling air to recirculate.
- D. Don't store or use chemicals close to the motor.
- E. A running motor that is too hot to touch is not necessarily overloaded. Class B motors have a maximum operating temperature of 130° centigrade (266° F).
- F. If pool or jet pump motors are removed from service at the end of a season, do not wrap them tightly in plastic. Temperature changes may cause condensation with detrimental effects.
- G. Thinner air at higher altitudes has less cooling ability. As a rule of thumb, the next higher horsepower rating may be used at altitudes above 3300 feet to compensate.

***Operating
Reminders***



A.O.SMITH
ELECTRICAL PRODUCTS
COMPANY

A DIVISION OF A.O.SMITH CORPORATION



531 NORTH FOURTH STREET
TIPP CITY, OH 45371
937) 667-6800
FAX: (937) 667-5873
www.aosmithmotors.com